



TGS 6x2 Midlift Tractor

Chassis Specification: TGS 26.400 6x2/2 BLS
 TGS 26.440 6x2/2 BLS
 TGS 26.480 6x2/2 BLS



MAN EGR: Add Nothing!

TGS 26.400 6x2/2 BLS Midlift Tractor TGS 26.440 6x2/2 BLS Midlift Tractor TGS 26.480 6x2/2 BLS Midlift Tractor

Chassis Specification

Base Cab Model

TGS 'L' Cab

For cab variants, options and specifications see separate TGS cab specification sheet

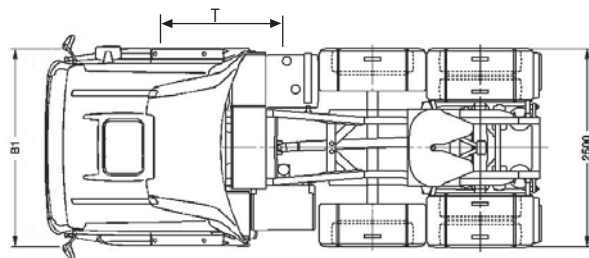
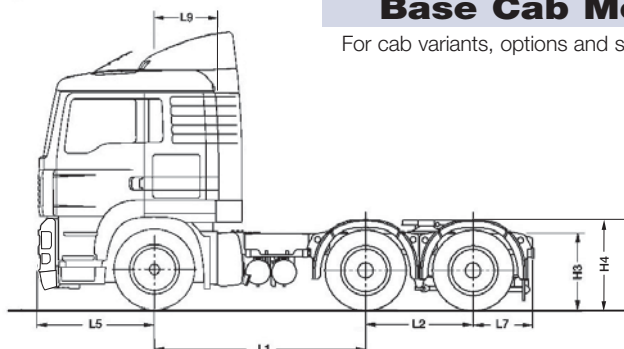

Vehicle Dimensions (mm)

L1	Wheelbase	2600
L2	Rear bogie spread	1350
L5	Front overhang	1475
L7	Rear overhang	800
L9	Centre line front axle to back of cab	805
B1	Width across wings	2500
H3	Frame height at centre rear wheels - laden	977
	- unladen	1007
H4	Standard 5th wheel height - laden	1240
	- unladen	1270
T	Centre of front axle to centre of fuel tank	1335

Turning Circle

WTW	Wall to Wall	14800
KTK	Kerb to Kerb	13100
	Optimum 5th wheel position for standard specification	935

Unladen Weights (kg +/- 2.5%)

Front axle	4740
Rear axle	2915
Total	7655

N.B. Unladen weights are for vehicle in standard specification with 25 litres of fuel and without driver.

Plated/Operating Weights (kg)

	Design	UK Legal
GCW Gross Combination Weight	50000	40000 ⁽¹⁾ /44000 ⁽²⁾
GVW Gross Vehicle Weight	26000	23700
Front axle	8000	7100
Midlift axle	7100	7100 ⁽¹⁾ /6500 ⁽²⁾
Drive axle	11500	11500 ⁽¹⁾ /10500 ⁽²⁾

N.B. Tyre changes can effect legal weights. ⁽¹⁾@ 40000 kg or below ⁽²⁾above 40000 kg.

Optional Equipment & Weights (kg)

	Front	Rear	Total		Front	Rear	Total
D26 Engine in lieu of D20 engine	+25	0	+25	Door extensions	+12	0	+12
Fixed 5th wheel	+14	-63	-49	Air Conditioning	+40	0	+40
16 Speed manual gearbox	+35	+30	+65	385/65R Super Single Tyres on			
ZF PTO NH/4	+4	+3	+7	11.75x22.5 steel rims on front	+38	0	+38
Alloy Air Tanks	-4	-11	-15	'M' Day cab	-216	0	-216
Windows in rear cab wall	+8	0	+8	'LX' Sleeper cab	+35	0	+35
9.00 x 22.5 Alcoa Alloy Wheels	-38	-114	-152	Lead up ramps	-7	+33	+26
3 piece steel bumper	+89	-25	+64	ADR Preparation	+40	0	+40
225 Ah Batteries	+30	0	+30				

Components weights are provided as a guide and may vary depending on make and manufacturing tolerances.

TGS 26.400 6x2/2 BLS Midlift Tractor

TGS 26.440 6x2/2 BLS Midlift Tractor

TGS 26.480 6x2/2 BLS Midlift Tractor



Chassis Specification

Engine Model	D2066LF37 400 PS	D2066LF36 440 PS	D2676LF05 480 PS
D20, 6 Cylinder in-line, 10.5 litre, Euro 4	400PS @ 1900 rpm 1900 Nm @ 1000-1400 rpm	440PS @ 1900 rpm 2100 Nm @ 1000-1400 rpm	480PS @ 1900 rpm 2300 Nm @ 1050-1400 rpm
D26, 6 Cylinder in-line, 12.4 litre, Euro 4			
Features	<ul style="list-style-type: none"> Exhaust Gas Recirculation (EGR) Common Rail EDC Cruise Control Exhaust valve brake Road speed limiter set not to exceed 56mph (90kph) On-board diagnostics with NO_x control 		

Performance							@44000 kg
Engine Power	Gearbox	Axle Ratio	Gear Road Speed (mph)	Engine RPM @55 mph	Engine RPM @53 mph	Starting Grade	Tyre Size
400PS	ZF 12AS2130 DD	3.08:1	73.2	1430	1375	31.6%+	295/80R22.5
440PS	ZF 12AS2130 DD	2.85:1	79.3	1320	1270	33%+	295/80R22.5
480PS	ZF 12AS2330 DD	2.85:1	79.3	1320	1270	33%+	295/80R22.5

Clutch

Single plate 430mm diameter, non asbestos

Axles

Steer	VOK-08 drop beam
Midlift Axle	LO-08 non steering
Drive Axle	HY-1350 single reduction

Braking System

Type	Electronic Brake System (EBS) with Anti-lock Braking System (ABS) and ASR traction control
Features	Vented disc brakes, 2 line trailer brake connections and pad wear indicators
Parking Brake	Spring brakes on rear axles

Gearbox

MAN Tipmatic 12 speed automated gearbox

Ratios

Forward					
1	15.86	2	12.33	3	9.57
4	7.44	5	5.87	6	4.57
7	3.47	8	2.70	9	2.10
10	1.63	11	1.29	12	1.00

Reverse
14.68

Suspension

Steer Axle	Parabolic Springs Hydraulic Dampers Stabiliser
Midlift Axle	2 Bag Air Hydraulic Dampers Air Operated Lift
Drive Axle	ECAS Controlled 4 Bag Air Hydraulic Dampers Stabiliser

Steering Gear

Type	ZF 8098 Servocom hydraulically assisted.
------	--

Manual Gearbox Options

ZF 16 speed gearbox, with range change and splitter.

Wheels & Tyres

Steer Axle	Tyres	295/80R 22.5 steer tread
	Wheels	9.00x22.5
Midlift Axle	Tyres	295/80R 22.5 steer tread
	Wheels	9.00x22.5
Drive Axle	Tyres	295/80R 22.5 drive tread
	Wheels	9.00x22.5

Exhaust System

Ground discharge silencer.
Incorporating MAN PM-KAT® Technology

Frame

Construction	Bolted and Riveted
Material	High tensile steel
Section	270 x 85 x 8mm 940 - 762mm waisted

General Equipment

Adjustable roof blade air management with cab side deflectors (sleeper models only)

Sliding fifth wheel and base plate

3 piece plastic rear wings and spray reduction mats

Catwalk

Hoses and couplings including ABS lead

Coupling lamp

Fuel Tank

Capacity	480 Litre
Section	Rectangular Aluminium with Integral Step RHS mounted Locking cap

Electrical System

Type	MANTronic CAN bus system with central on board computer and vehicle management computer
Voltage	24v
Alternator	80 Amp
Batteries	2 x 12v 175Ah

MAN ERF UK Ltd.,
Frankland Road, Blagrove,
Swindon. Wiltshire SN5 8YU
www.man-mn.co.uk

A member of the MAN Group.

